

Double Parking Lift Unipole

PARKING PROBLEMS? NO SPACE? NOW DOUBLE THE AVAILABLE SPACE WITH NANDAN'S DOUBLE PARKING LIFT



Salient Features:

- ✓ Single pole design is aesthetically pleasing
- ✓ Sturdy design in cold formed sheets made in high strength ST-52
- ✓ Almost zero maintenance
- ✓ No chains or ropes (like cheaper competition that leads to accidents)
- ✓ Hydraulic lifting
- ✓ One powerpack can drive multiple units
- ✓ Designed in 3 D modeling and Design has been FEA validated in ALGOR

Applications:

Industrial Estates
Residential Bldg
Car Showrooms
Car Warehouse
Government
Commercial
Malls
Offices
Parking
Hotels
Events

NANDAN
Group

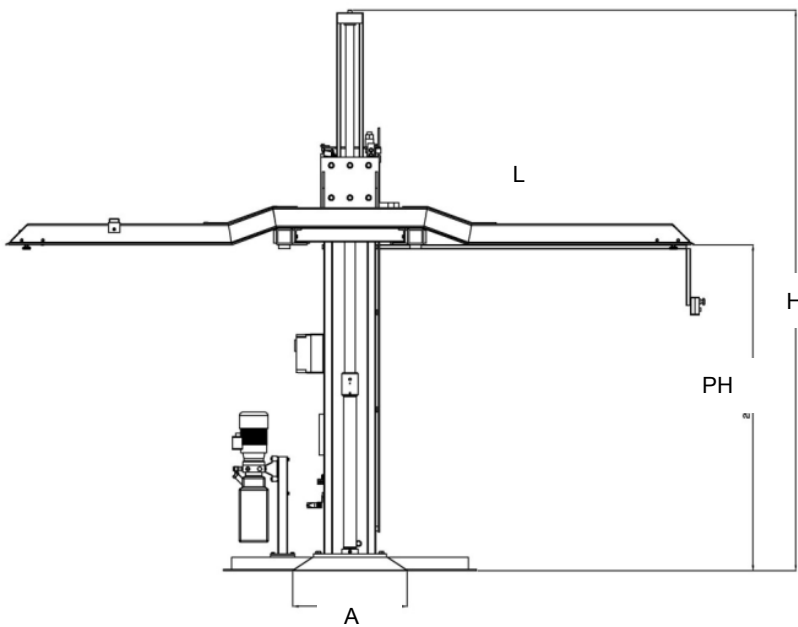

TYPE

Unipole Cantilevered Double Parking Lift

OVERALL DIMENSIONS

4000mm (L) x 2600mm (W) x 2600mm (H)

INSTALLATION AREA NECESSARY

4000mm (L) x 2600mm (W) x 3300mm (H) with concrete floor

CAPACITY

2500kg on platform of 4000mm x 2000mm lifting to height of 1800mm(PH)

OPERATIONS

Electrohydraulic by key, 45 sec total lift time 3 phase motor

SAFETY

Pilot check valve, direct lifting by cylinder, arch in center to prevent rolling, mechanical lock in the maximum position to secure car platform

OPTIONS IN ORDERING

Sensor under platform for safety
"Auto-Lock" for wheels

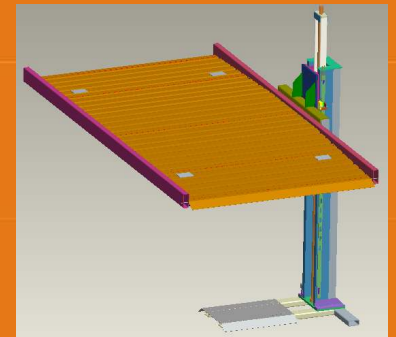
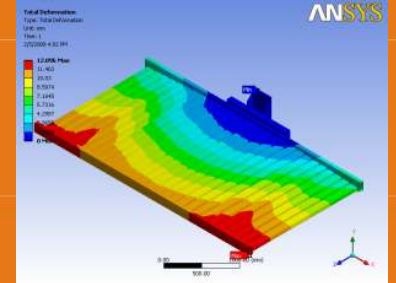

NANDAN GSE PVT. LTD.

D-205 MIDC Turbhe, Navi Mumbai 400705 INDIA

Ph: +91-22-27635508/ 09 | Fax: +91-22-27635510

e-mail: info@nandan.com | website: www.nandan.co.in