

MARS
ALMOST Rocket Science



Class 2 Safety Cabinet

Advanced design for
your safety and comfort



SCANLAF

MARS

ALMOST Rocket Science

The first journey to the moon in 1962 initiated by John F. Kennedy, led to the advancement of HEPA-filter technology. Today's motivation is to go to Mars before 2020 - this takes the technology, with the aid of "Rocket Science" beyond believable levels of today. Our Class 2 cabinet MARS is designed with this in mind, for your safety and comfort.

Operator comfort

High angled front window allows easy supervision of the samples and work area also giving an ergonomically correct working position when seated. With side windows, glare free rear wall and easy visibility of the surroundings ensures a comfortable working environment. Diffused laminator technology allows shadow free light distribution throughout the chamber with light adjustment of 0-2000 Lux. illumination.

The provision of non restricted air, 3 digital blowers which are easy to adjust precisely, the diffuser technology of true laminar flow with deviations of less than 10% high. High capacity HEPA-filters of 11 cm allows lowest noise level of less than 54 dBA - generally every 3 dBA reduction leads to half noise.

The electrical hoisted window with one button operation allows easy cleaning of the window in 0% position and easy decontamination in 100% position

Operator safety

V-shaped air inlet grills - allows for air to pass the operators arms without restricting the safety grills and guards against incorrect use of table top thereby maintaining operator safety.

Down flow and exhaust air are monitored with airflow sensors ensuring optimum safety at all times. Visual and acoustic alarms alerts the operators of unsafe airflow conditions. If the cabinet is externally ducted a 3rd pressure sensor can be located in the exhaust duct to warn the operator of insufficient exhaust air and this also includes potential free contacts

Running costs

Digital Technology gives the benefits of low energy consumption at 0.9 Amp. Having 3 blowers as compared to 2 or 1 blower, equates to less restricted construction and allows the use of 11 cm deep HEPA-filters. The low volume cabinet construction saves unnecessary movement of expensive air - prolonging the life of HEPA- filters and blowers. The low energy consumption also gives low energy transmission to the work chamber, which in turn gives temperature increase of less than 1° C - thus lowering evaporation rates from samples and saves on expensive air conditioning of the room.

Slim, compact design

A slim compact design, total depth of less than 80 cm, allows easy installation and relocation without any need of disassembly.

The low cabinet height allows the operator freely to decide on table top location or support stand - . (A re-circulating cabinet should have a minimum 20 cm of space above the cabinet to allow for non - restricted exhaust air flow). MARS is only 2.0 meter high with work position of 75 cm when on support stand

Operator comfort



Operator safety



Running costs



Slim design



Compatible



Designed for most applications

The cabinets versatility of design allows for weighing applications in the work chamber, weighing to 4-5 decimals and with an anti-vibration platen down to 6 decimals. With a max operational work height of the window position at 30 cm. operator safety is maintained. The cabinet can also integrate microscopes with full operator integrity and product sterility.

Heating mantels - electrically or enclosed water circulation - are available with the size decided by the customer.

The cabinet is available with lead glass solutions for work with isotopes. The design includes lead cover of the trough from 3 mm to 3 cm. A sliding clear lead window taking away the use of lead bricks from 3mm to 3 cm. Or any other protection as required

Working with viruses, cyto-toxics? There is the option of the MARS cabinet fitted with a 3rd HEPA filter - the MARS PRO. Working with volatile compounds or solutions? Whatever the "problem" we have the safe answer!

Service

All service is performed from the front of the cabinet.

Including exchange of HEPA-filters, exchange or adjustment of circuit boards and sensors.

All alarms and fan speeds changes are adjusted from the microprocessor control panel

Includes DOP valves

Cleanroom design

The cabinet is designed for easy cleaning inside with corners radiused and contoured.

Externally the cabinet is constructed on a box design concept with no screws and knops, for easy cleaning.

If required the cabinet can be wall hanged saving valuable floor space.

Airflow pattern

The Mars cabinet utilizes a revolutionary new design of having 2 downflow fans and one exhaust fan with 110mm deep HEPA filters. This allows for lower noise levels, better air distribution and longer filter life. When used together with our unique laminator technology the downflow air is better balanced and more uniform ensuring superior product protection under turbulence free laminar flow air atmosphere.

The work surfaces. Antivibration characteristics also improves operator comfort. Noise levels are further reduced and filter life extended by having the downflow speed set at 0.32m/s +/-10% (min 0.32 m/s) compared to others at 0.40m/s +/- 20% (min 0.32m/s). The digital blower system is controlled directly and precisely from the microprocessor. This improves velocity control and ensures the monitoring and warning of any malfunctions. The cabinet can easily be adjusted from the service mode by authorized personnel. Down flow speeds can be adjusted from 0.25 m/s up to 0.55 m/s.

Easy cleaning



Compact design

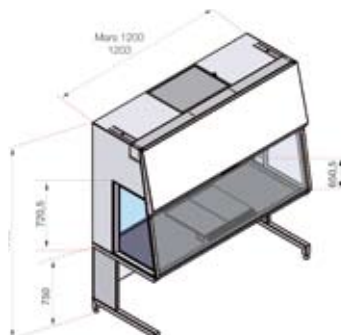

Airflow pattern

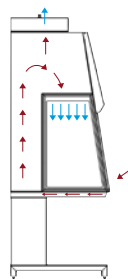

Microprocessor control



USB port



Microprocessor control

A digital fan allow precise direct setting of fan speed and gives up to 75% more power compared to similar analogue units. The noise levels are much lower - the energy consumption correspondingly lower. Air flow meters are used for the direct control of the down flow air and the exhaust air. Also a pressostat measurement can be added. Pressure measurement is an indirect measurement and can therefore be used as an indicator of any HEPA filter blockage. The air flow speeds may be read out. Energy saving reduced speed for fast, easy and safe start up of the cabinet. And for maintaining cabinet integrity whilst unattended. Decontamination programme for either Formalin or VHP.

A 3rd sensor option allows measurement of the pressure drop in the exhaust ducting. Giving a signal back to the operator - warning if exhaust air is insufficient. This can be a problem when a common ducting is used for multiple cabinets and/or fume hoods.

USB-port

USB port option makes it possible for monitoring and documenting the full performance of the cabinet on PC - for GMP work- the daily logging of air flow speeds, alarms, settings, which functions are used where and when....This is an open communication platform working with external control units, BMS systems etc..

Eye Level control panel

All cabinet functions can be viewed from either a seated or standing position without upsetting working procedures. The control panel includes functions for reduced speed, resettable hour counter, light and UV-timer, exhaust, down flow and window alarms. Service access is protected via a key pad code. The digital blower system and alarm settings are precisely controlled through the microprocessor giving excellent airflow performance.

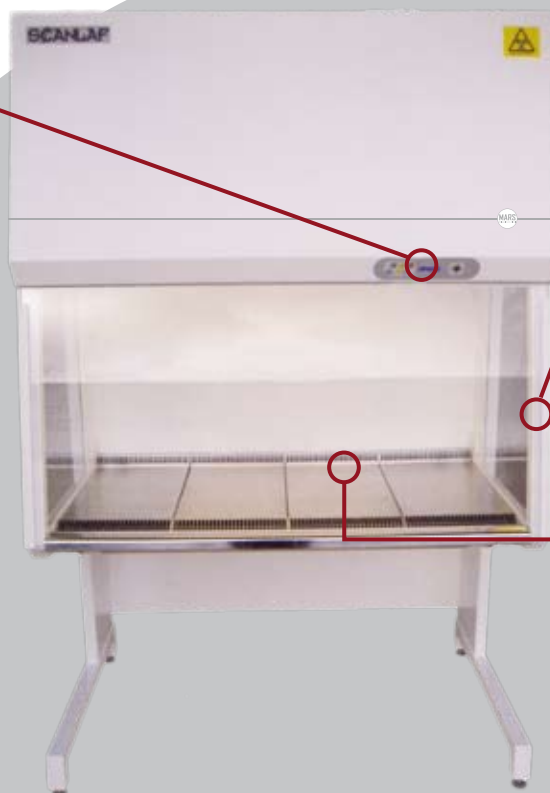

High work opening.

The normal work opening is a comfortable 20 or optional 30 cm giving the best operator barrier. Often weighing applications require higher working heights to get access to containers etc. therefore the cabinet is made with an option to have a work opening of 30 cm.

Compact

Being only 799 mm deep, the cabinet can easily be transported through 800 mm doorways. The compact design also saves on valuable laboratory space. The cabinet is available in 4 sizes 900, 1200, 1500 and 1800 working widths.

Accessories

A wide accessory program is available and the modular build design allows for the fitting of microscopes, heated work tops, waste systems, freeze dryers, table tops for animal care etc.

Product	
9.001.023.000	Mars 900
9.001.020.000	Mars 1200, TÜV approved
9.001.022.000	Mars 1500
9.001.021.000	Mars 1800, TÜV approved
9.002.023.000	Mars 900 Pro incl supportstand work height 75 + 5 cm
9.002.020.000	Mars 1200 Pro incl supportstand work height 75 + 5 cm
9.002.022.000	Mars 1500 Pro incl supportstand work height 75 + 5 cm
9.002.021.000	Mars 1800 Pro incl supportstand work height 75 + 5 cm
Accessories	
Valves	Please select window type with remark left/right for each
9.000.020.105	Window in hardened glass with 3 holes for valves
9.000.020.106	Window in hardened glass with no holes
9.000.020.107	UV-light mounted on the front top of the cabinet Mars
9.000.020.108	Window in hardened glass with 1 hole for valve
9.000.020.198	Window in stainless steel painted white
9.000.020.015	Valve, gas
9.000.020.016	Valve, vacuum
9.000.020.017	Valve, carbon dioxide
9.000.020.018	Valve, nitrogen
9.000.020.019	Valve, pressurised
9.000.020.020	Valve, oxygen
9.000.020.030	Gas resetable solenoid valve - please add to gas-valve
El-outlets	Mounted in the cabinet - always order min 1 left and 1 right
9.000.020.021	Electric outlet, single Danish left
9.000.020.022	Electric outlet, single German left
9.000.020.023	Electric outlet, single British left
9.000.020.024	Electric outlet, single French left
9.000.020.025	Electric outlet, single Swiss left
9.000.020.026	Electric outlet, single US left
9.000.020.027	Electric outlet right side mounting as left side
Support stand	Please choose none or the stand for wanted work height
9.001.020.011	Adjustable support stand 75-80 cm M900
9.001.020.012	Adjustable support stand 75-80 cm M1200
9.001.020.013	Adjustable support stand 75-80 cm M1500
9.001.020.014	Adjustable support stand 75-80 cm M1800
9.001.040.011	Adjustable support stand 80-85 cm M900
9.001.040.012	Adjustable support stand 80-85 cm M1200
9.001.040.013	Adjustable support stand 80-85 cm M1500
9.001.040.014	Adjustable support stand 80-85 cm M1800
9.001.030.011	Adjustable support stand 90-95 cm M900
9.001.030.012	Adjustable support stand 90-95 cm M1200
9.001.030.013	Adjustable support stand 90-95 cm M1500
9.001.030.014	Adjustable support stand 90-95 cm M1800
9.001.020.101	Electrical elevation stand 75-105 cm M900
9.001.020.102	Electrical elevation stand 75-105 cm M1200
9.001.020.103	Electrical elevation stand 75-105 cm M1500
9.001.020.104	Electrical elevation stand 75-105 cm M1800
9.001.020.108	Wall hanging for hanging the cabinets on the wall

Table tops	As standard supplied w/divided 30 cm tabletops in AISI304- order below and these table top are exchanged correspondingly
9.001.020.405	Straight one piece table top for M900 add
9.001.020.406	Straight one piece table top for M1200 add
9.001.020.407	Straight one piece table top for M1500 add
9.001.020.408	Straight one piece table top for M1800 add
9.001.020.409	Divided table tops AISI 316L M900
9.001.020.410	Divided table tops AISI 316L M1200
9.001.020.411	Divided table tops AISI 316L M1500
9.001.020.412	Divided table tops AISI 316L M1800
9.001.020.413	Table top in stainless AISI 304 600mm wide
9.001.020.414	Table top in stainless AISI 316L 600mm wide
9.001.020.415	Table top in stainless AISI 316L 900 mm wide
Exhaust systems	
9.001.020.109	Double HEPA Exhaust Filter
9.001.020.110	Activated Carbon Exhaust Filter
9.001.020.118	Antiblow back valve side ducting angled Ø 200mm M900/1200
9.001.020.119	Antiblow back valve side ducting straight Ø 200mm M900/1200
9.001.020.120	Antiblow back valve side ducting angled Ø 200 mm M1500/1800
9.001.020.121	Antiblow back valve side ducting straight Ø 200 mm M1500/1800
9.001.020.122	Ducting plate w/ Ø 200 mm for external vent. M900/1200
9.001.020.123	Ducting plate w/ Ø 200 mm for external vent. M1500/1800
9.001.020.129	Carbonfilter for exhaust casings
9.001.020.201	Signals for external ventilation system
9.001.020.202	3-sensor option with pressure switch
Fumigation	
9.001.020.115	Formalin fumigation kit incl.top close plate and programming
9.001.020.116	VHP fumigation kit incl. valves, top close plate and programming
9.001.020.117	Formalin evaporizer system - for mounting in side window
9.001.020.128	Double exhaust casing no HEPA filter for Decon without exhaust options
9.001.020.131	Side ducted top plate incl manual damper for double exhaust
9.001.220.134	Top plate with VHP Valve for fumigation, double exhaust casing
9.001.200.136	VHP valve 1 piece
9.001.020.130	Lockable exhausts valve - airtight - manual
9.001.020.140	Lockable exhaust valve - airtight - automatic
Other accessories	
9.001.020.127	USB port for communication with computer incl software package
9.001.000.088	Bunsen burner with foot switch
9.001.020.126	Zink 325 x 325 x 200 in stainless 304 with water tap specify left or right
9.001.020.112	LAF-LCD Screen 19 inches with magnetic mounting 2.5 m cables

9.001.020.114	Minihelic mounted on the backwall for guidance of safety
9.001.020.124	4 Castors lockable for mounting on support stands
9.001.020.200	Sectioned antivibration support and marble stone 250x250 mm
9.001.200.135	Armrest 2 pices Holten type
9.001.020.125	Heatplatezone system 300 x 450 mm with circulator and practical shelf
9.001.040.015	Prefilternet with EU-3 for Mars 900
9.001.040.016	Prefilternet with EU-3 for Mars 1200
9.001.040.017	Prefilternet with EU-3 for Mars 1500
9.001.040.018	Prefilternet with EU-3 for Mars 1800
9.001.000.087	Pir-sensor - turns automatically to full speed and light upon any movement
Service	Standard factory test is air velocity, ballometer exhaust and particle counting
9.000.050.250	Factory test Maxi normal plus sound, light, fotometer test
9.000.050.255	Factory KI test
9.000.050.257	IQ-OQ document inclusive factory fill out
Lead option	
9.001.220.131	Sliding Lead window 35 x 40 cm 7 mm corresponds to 3 mm lead on 1 m rail
9.001.220.132	Through protected with 3 mm lead and covered by metal shield M900
9.001.220.133	Support stand reinforced for lead cabinets M900
Packing and	
9.000.070.001	Mars 900, cardboard
9.000.070.002	Mars 1200, cardboard
9.000.070.003	Mars 1500, cardboard
9.000.070.004	Mars 1800, cardboard
9.000.070.005	Mars 900, wooden
9.000.070.006	Mars 1200, wooden
9.000.070.007	Mars 1500, wooden
9.000.070.008	Mars 1800, wooden



USB port facility



Weighing applications



Gas valve



Bunsen burner with foot switch



Table tops



Exhaust systems

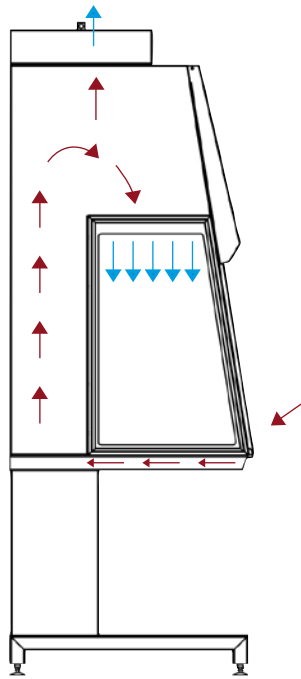

Class 2 Airflow diagram showing true turbulent-free laminar air-flow that provides operator, product and environmental protection, with lowest noise level available today

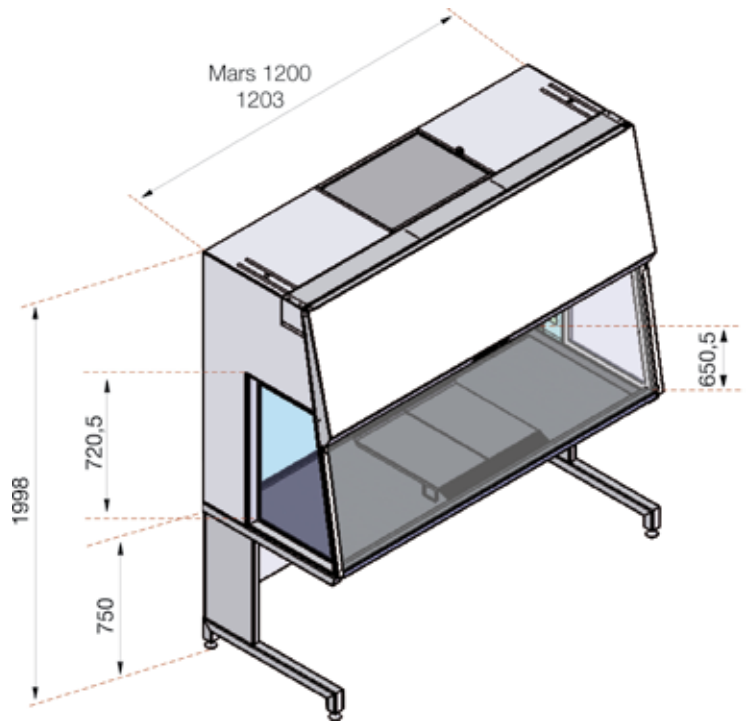

Dimensions of MARS 1200 illustrating the unique slim-line design with divided sectional worktop and large working enclosure enabling organised safe working practices and ease of cleaning

Technical specifications

Model	Unit	M-900	M-1200	M-1500	M-1800
Catalogue no.		9.001.023.000	9.001.020.000	9.001.022.000	9.001.021.000
External dimensions (DxWxH)	mm	798x1003x1248	798x1303x1248	798x1603x1248	798x1903x1248
Working chamber, dimensions (DxWxH)	mm	650x900x720	650x1200x720	650x1500x720	650x1800x720
Working height	m	Work height off 0.75-1.10 in 2.50 rooms			
Front opening	mm	200 optional 300			
Air velocity, vertical flow	m/s	0.30 (adjustable 0.25-0.55)			
Air velocity, deviation	±%	10			
Down flow rate	m ³ /h	500	650	810	975
Exhaust flow rate	m ³ /h	260	350	440	520
Noise level, ISO 6081	dB(A)	<53	<54	<56	<57
Light intensity variable	Lux	0-2000			
HEPA filters, EN 1822		Efficiency is 99.999% against 0.3 µm particle H-14 size 99.995% in MPPS			
V-shaped table tops		Yes			
Clean room box design		Yes			
Excellent light distribution		Yes			
Electrical sliding windows		Yes			
Window cleanable on both sides		Yes (side windows only if space around allows cleaning)			
Voltage/frequency	V/Hz	220-240/50-60 or 110-120/50-60			
Power consumption	W	150	175	200	225
Fuses	A	10			
Net weight	kg	225	250	275	300
Shipping volume	m ³	2.2	2.9	3.2	4.1
Window material		Hardened/laminated safety glass			
Cabinet material		Polyester coated steel/AISI 304 Stainless steel			

ScanLaf is a Danish company specialising in the development, production and sales of laboratory and industrial equipments encompassing the following technologies:

Laminar Flow, Vacuum & Cooling.

All our staff have a long and successful heritage from the well known Heto-Holten A/S™ company from which today's portfolio of equipments have been developed.

The new ScanLaf range of equipments are the successors to this legacy and a majority of the accessories provided today are compatible with instrumentation you may already have in your laboratory.

ScanLaf A/S presents to you probably the best in Class 2 and laminar flow Cabinets and technology available today. Together with the ScanVac range of world class Freeze Dryers, Speed Vacuum Concentrators and cooling baths.

Industrial Laminar Flow

Clean Air installations, incorporating down-flow and recirculating down flow modules for powder or animal handling are part of our customised solutions for industrial or laboratory applications. Glove-Boxes and Air Shower constructions, on a bespoke basis, are our force and expertise that is available in consultation with our Technical Team.

Our Service Organisation and network of selected distributors offer complete back-up and support as well as service.

We look forward to co-operate with you.

™ trade name/mark owned by Thermo Corporation.

