

FMD52

Features

Oil Impregnated for Good Corona Resistance
 Dielectric - Polypropylene + Paper
 Electrode - Aluminium Foil
 Coil - Non-inductively wound, mineral oil impregnated
 Leads - Brass stud
 Construction - Aluminium can + Blue PVC Sleeve,
 stud insert moulded plastic end caps
 Markings - El-Ci-Ar logo, Capacitance, Voltage, Type
 Capacitor Tolerance - 20% (M), 10% (K), 5% (J)
 Dissipation Factor ≤ 0.005 at 1KHz at 25C (Typical Value 0.001)
 Test Voltage - $2.5 \times V_r$ for 2 sec



Max Pulse Rise - 300V/usec
 Temperature Range from -25°C to $+85^{\circ}\text{C}$
 Insulation Resistance $\geq 25 \text{ G}\Omega$ for $C \leq 0.33\mu\text{F}$ At 20C
 $\geq 3000 \text{ sec}$ for $C \geq 0.33\mu\text{F}$

Available Values

Capacitance - 0.1uF to 2uF
 Voltage - AC Rating 1200VAC
 DC Rating 2000VDC

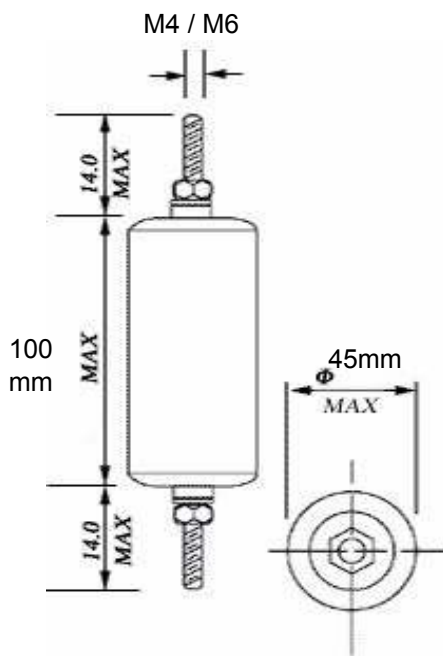

Value (uF)	Diameter	Length	Stud
0.1	19	40	M4
0.25	25	72	M6
0.5	30	72	M6
1	40	100	M6
2	45	100	M6

Applications

For forced commutation of SCRs such as in inverters and choppers these capacitors are ruggedly designed to carry heavy currents. They employ a non-inductively wound oil impregnated paper polypropylene mixed dielectric coil with aluminium foil as electrode. Encased in aluminium can and offered in axial threaded screw terminals these are generally popular in values from 0.1 uF to 2 uF and in voltage rating of 1200 VAC. A special construction feature provides for an explosion proof performance through the means of an open circuiting of the element when excessive current flows through the capacitor under fault conditions.