

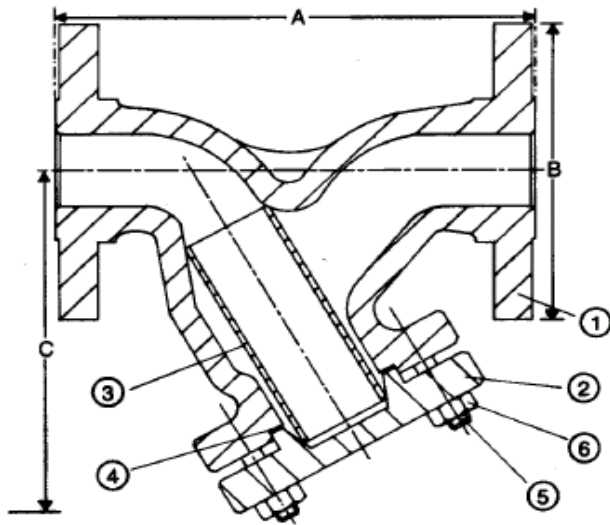

# C.S. "Y" STRAINER

# ALFA INDUSTRIAL EQUIPMENTS



### PARTS AND MATERIAL (ASTM)

NO.	PARTS NAME	MATERIALS				
		WCB	LCB	WC6	S.S. 304	S.S. 316
1	Body	A216-WCB	A352-LCB	A217-WC6	CF8	CF8M
2	Cover	A216-WCB	A352-LCB	A217-WC6	CF8	CF8M
3	Screen	A 304				A 316
4	Gasket	Compressed Asbestos Fiber (CAF)			PTFE / spiral wound	
5	Cover Stud	A193-B7				
6	Cover Nut	A194-2H				

OTHER MATERIALS ARE AVAILABLE UPON REQUEST.

### DIMENSION TABLE:

DIM SIZE	A	B											C	
		BS Table				ANSI			DIN-ND					
		F	H	J	K	150	300	600	10	16	25	40		
NB														
40	235	140	140	140	152	127	155	156	150	150	150	150	187	
50	254	165	165	165	165	152	165	165	165	165	165	165	203	
80	330	203	203	203	203	190	210	210	200	200	200	200	245	
100	381	216	229	229	241	229	254	273	220	220	235	235	299	

### PRESSURE RATING IN Kg/cm<sup>2</sup>:

Flange Type	Size							
	40NB		50 NB		80 NB		100 NB	
	Kg/cm <sup>2</sup>	°C	Kg/cm <sup>2</sup>	°C	Kg/cm <sup>2</sup>	°C	Kg/cm <sup>2</sup>	°C
BS 10 Table H	17.60	427	17.6	427	17.6	427	-	-
BS 10 Table K	31.63	427	31.63	427	31.63	427	31.63	427
ASA – 150	10.50	260	-	-	-	-	10.50	260
ASA – 300	25.67	427	25.67	427	-	-	25.67	427
ASA – 600	42.18	427	-	-	-	-	-	-
DIN ND – 40	40	120	40	120	40	120	40	120

### Screen details:

Fitted as standard with s.s. Screen having perforations of 0.8 mm dia. With 3 mm dia. Perforated backing 40, 60, 100, 200 mesh screen is available as special on request.

### Servicing:

With suitable isolation, repairs can be carried out line. Undo nuts and remove strainer cap. Remove muck and clean screen thoroughly. Fit screen carefully and fit cap with the new gasket. Apply a thin coating of jointing paste. Tighten nuts uniformly. Open up isolation valve. Check for gasket leak if any and tighten.

### Optional:

15 NB BSPT plug on cover is available on request.

### Installation:

The arrow on casting indicates flow direction.



# ALFA INDUSTRIAL EQUIPMENTS

TEL: +91 022 25463439 FAX: +91 022 28509836 E-mail: [alfa\\_aie@yahoo.com](mailto:alfa_aie@yahoo.com)



# C.I. "Y" STRAINER

# ALFA INDUSTRIAL EQUIPMENTS

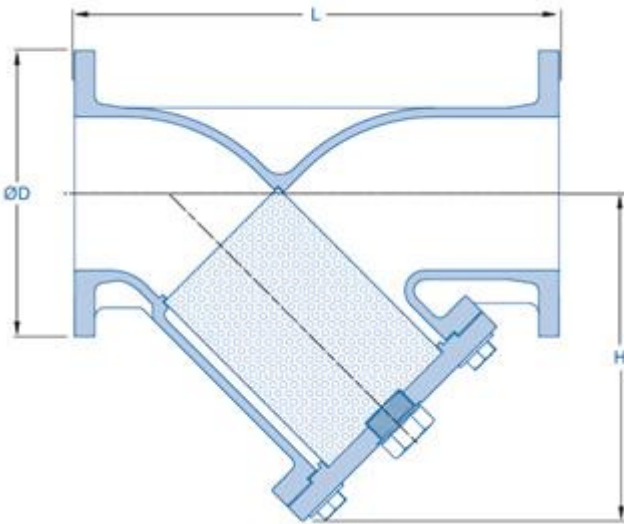

## PARTS AND MATERIAL

NO.	PARTS NAME	MATERIALS	STANDARD
1	Body	Cast Iron	BS 1452 Gr. 14
2	Cover	Cast Iron	BS 1452 Gr. 14
3	Screen	Stainless Steel Type 304	ASTM A-240
4	Gasket	EPDM / NBR	Commercial
5	Cover Stud	Carbon Steel	IS 1367
6	Cover Nut	Carbon Steel	HT IS 1367 Gr. B

Other materials are available upon request.

## DIMENSION TABLE:

SIZE	L	D				H Approx
		BS-10 Table	ANSI	DIN-ND		
NB		F	150	ND 10	ND 16	
40	173	140	127	150	150	159
50	200	165	152	165	165	179
80	264	203	190	200	200	225
100	327	229	229	220	220	267
150	390	305	279	285	285	367
200	460	368	343	340	340	470

\* **Note;** General Tolerance up to 80 NB  $\pm 3$ , above 80 NB  $\pm 5$   
Alternative flange drillings may be available on request.

## PRESSURE RATING IN Kg/cm<sup>2</sup> at 80 °C

FLANGE TYPE	SIZE					
	40 NB	50 NB	80 NB	100 NB	150 NB	200 NB
BS 10 Table - F	10.55	10.55	10.55	10.55	10.55	10.55
ASA - 150	10.55	10.55	10.55	10.55	10.55	10.55
DIN ND-16	16.00	16.00	16.00	16.00	16.00	16.00

### Screen details:

Fitted as standard with s.s. Screen having perforations of 0.8 mm dia.  
With 3 mm dia. Perforated backing 40, 60, 100, 200 mesh screen is available as special on request.

### Servicing:

With suitable isolation, repairs can be carried out line. Undo nuts and remove strainer cap. Remove muck and clean screen thoroughly. Fit screen carefully and fit cap with the new gasket. Apply a thin coating of jointing paste. Tighten nuts uniformly. Open up isolation valve. Check for gasket leak if any and tighten.

### Optional:

15 NB BSPT plug on cover is available on request.

### Installation:

The arrow on casting indicates flow direction.



**ALFA**  
INDUSTRIAL EQUIPMENTS

TEL: +91 022 25463439 FAX: +91 022 28509836 E-mail: [alfa\\_aie@yahoo.com](mailto:alfa_aie@yahoo.com)