

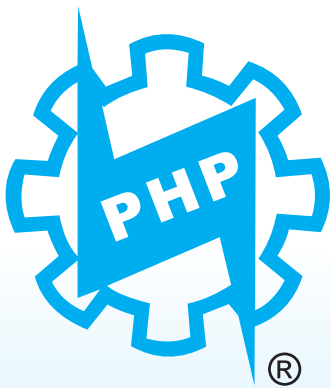

# *TUBULAR HEATERS*

*For Hot Runner Manifolds*



Estd. 1969  
Mumbai, INDIA

**PRATIK HEAT PRODUCTS**  
P R I V A T E L I M I T E D  
MANUFACTURERS & EXPORTERS OF QUALITY INDUSTRIAL HEATING ELEMENTS

***The first choice, to last.™***

# TUBULAR HEATERS

## DESCRIPTION

Formed Tubular Heaters can be supplied in either Stainless Steel 321 with nominal sheath diameter of 6.50mm and 8.00mm. Standard elements have a terminal post which gives a cold section of approx 30mm for 6.50mm and 35mm for 8.00mm.

The helical wound heating wire is made of a high temperature resistant NiCr alloy. And the insulation consists of superior grade of magnesium oxide (MgO). As the heaters are swaged, even at high sheath temperature they have excellent electrical insulation and a high heat transfer. To prevent the heater from moisture the connection ends are sealed with sealing components.

For manufacturing formed elements it is necessary to have a accurate dimensional sketch showing all the centre distances, radius and degrees, thus they need to be provided while placing the order.

## TECHNICAL DATA

	ø 6.5mm	ø 8.mm
Length	300 - 1550mm	400 - 2100mm
Maximum Current	12 A	15 A
Nominal Voltage	< 230V	< 400V
Wattage	±10%	±10%
Dielectric Strength	1.5HV	1.5 HV
Insulation MΩ	>5 MΩ	>5 MΩ
Leakage Current	<0.1 mA	<0.1 mA
Minimum Unheated	30mm	35mm
Terminal Pins	M3 x .50mm/ plain post	M4 x .70mm

Length Tolerances: ± 2%  
Diameter Tolerance: + 0.05mm  
- 0.10mm

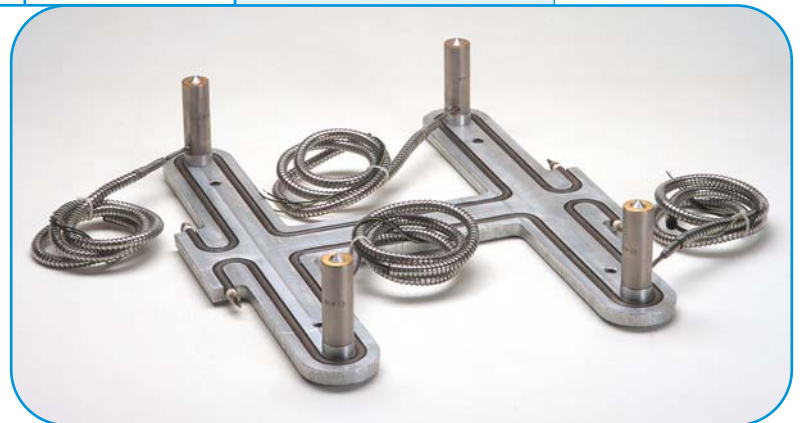

Formed Tubular Heater set in a manifold.

During designing the formed Tubular Heaters this fact should be stated in the order.

The minimum radius for  $\phi$  6.5mm is 12mm and for  $\phi$  8mm is 15mm.

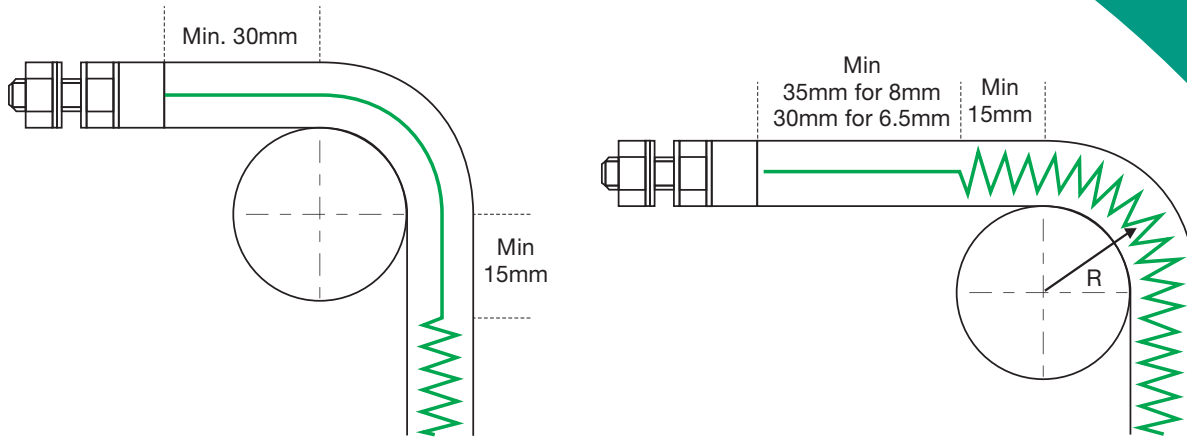

## DIMENSIONAL DATA

SS 321 Sheathed Tubular Heaters based on 60 watts/inch

Diameter	Length	Watts	Voltage	Diameter	Length	Watts	Volts
6.5	350	550	230	8	400	800	230
	375	600	230		450	900	230
	400	650	230		500	1000	230
	425	700	230		550	1150	230
	450	750	230		600	1250	230
	500	800	230		650	1400	230
	550	900	230		700	1500	230
	600	1000	230		750	1600	230
	650	1100	230		800	1750	230
	700	1200	230		850	1850	230
	750	1300	230		900	1950	230
	800	1350	230		950	2100	230
	850	1450	230		1000	2200	230
	900	1550	230		1050	2300	230
	950	1650	230		1100	2450	230
	1000	1750	230		1150	2550	230
	1050	1850	230		1200	2650	230
	1100	1950	230		1250	2800	230
	1150	2050	230		1300	2900	230
	1200	2100	230		1350	3000	230
1250	2200	230	1400	3150	230		
1300	2300	230	1450	3250	230		
1350	2400	230	1500	3350	230		
1400	2500	230	1550	3500	230		
1450	2600	230	1600	3600	230		
1500	2700	230	1650	3600	230		
1550	2800	230	1700	3600	230		
			1750	3600	230		
			1800	3600	230		
			1850	3600	230		
			1900	3600	230		
			1950	3600	230		
			2000	3600	230		
			2050	3600	230		
			2100	3600	230		

Tolerances for both diameters  
 Length +/- 1.0%  
 Wattage +/- 10%  
 Diameter -0.1mm to +0.05mm

Non working length for 6.5mm is 30mm each end (non bendable, included in sheath length)

Non working length for 8.0mm is 35mm each end (non bendable, included in sheath length)

$$KW = \frac{Wt \text{ of metal/plastic in kgs} \times Sp \text{ heat} \times \text{temp rise in celsius (final-ambient)}}{560 \times \text{heat up time in Hrs}} \quad \text{Add 20\% heat loss to the total KW}$$

### How to order

Please send a CAD or PDF drawing file showing all center distance along with the total path length, wattage, voltage and required quantity.

## PRECAUTIONS & INSTALLATION

1. Incorrect wiring and loose contacts leads to sparks resulting in fire or heater failure. Keep all electrical connections properly protected to avoid electrical hazards to machine operators. 2. Use of voltage stabilizers and Circuit breakers ensures smooth supply of voltage to heaters resulting a longer life. 3. Ensure that the terminal junction is technically engineered to withstand the ampere load as well as the shocks and jerks due to movements. Appropriate connection leads (insulated) to withstand the required ampere load also reduce the risk of heater failure. 4. Ensure that the terminals are well insulated and protected since the heater terminals are prone to attracting moisture. Combustible gases & vapours also leads to deposits of carbon on the terminals resulting in failure of heaters. 5. Raw materials (polymers) spilling on the terminals & contamination (oil/grease) penetrating the heaters. Prior to installation, the area must be cleaned & should be free of all contamination that might liquefy under heat and penetrate into the heaters thereby carbonizes & becomes conductive. The smallest amount of contamination can cause electrical shorts and result to heater failure. 6. In case of immersion heaters we recommend you to clean (De-scale) the heaters on regular intervals. This helps increase life of heaters as well as optimum achievement of temperature in a shorter period, there by saves power. 7. Overheating that leads the heater to operate beyond the maximum capacity can be a cause for destroying an entire heating zone, defect temperature sensors and controllers. The wattage should be calculated as close as possible to operating wattage to minimize on-off cycle resulting to power saving. Ensure that the tips of the sensors (Thermocouples) are clean and free from any contamination and should be checked for good response to temperature changes. 8. Use of substandard raw materials & manufacturing defects is also one of the common cause of heater failure.



EXPORTS TO 25 COUNTRIES ACROSS THE GLOBE

**PRATIK HEAT PRODUCTS**  
P R I V A T E L I M I T E D  
MANUFACTURERS & EXPORTERS OF QUALITY INDUSTRIAL HEATING ELEMENTS

### Registered Office & Works:

11/12, Tankiwala Industrial Estate, Steel Made Compound,  
Marol Maroshi Road, Andheri(E), Mumbai 400 059. INDIA.  
Phones : +91-22-29200183 / 29200189 / 29204284  
Fax : +91-22-2925 4309 Email : sales@phpheat.com

[www.phpheat.com](http://www.phpheat.com)

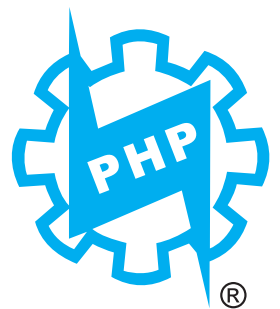

Estd. 1969  
Mumbai, INDIA